



724 SERIES™, 4724 SERIES™

STAINLESS STEEL CONSTRUCTION | UNIVERSAL PRODUCT LINE



FEATURES & BENEFITS

- Cast iron mounting bracket lowers overall pump cost (316SS wetted parts)
- Behind the rotor mechanical seal eliminates the shaft and bushing from being exposed to media
- Jacketed bracket provides the ability to maintain uniform temperature to sealing area

Jacketing for steam, hot oil or hot water circulation to maintain a uniform temperature around sealing area

Internal relief valve standard on G sizes and larger; optional plain head, jacketed head and jacketed relief valves on most sizes

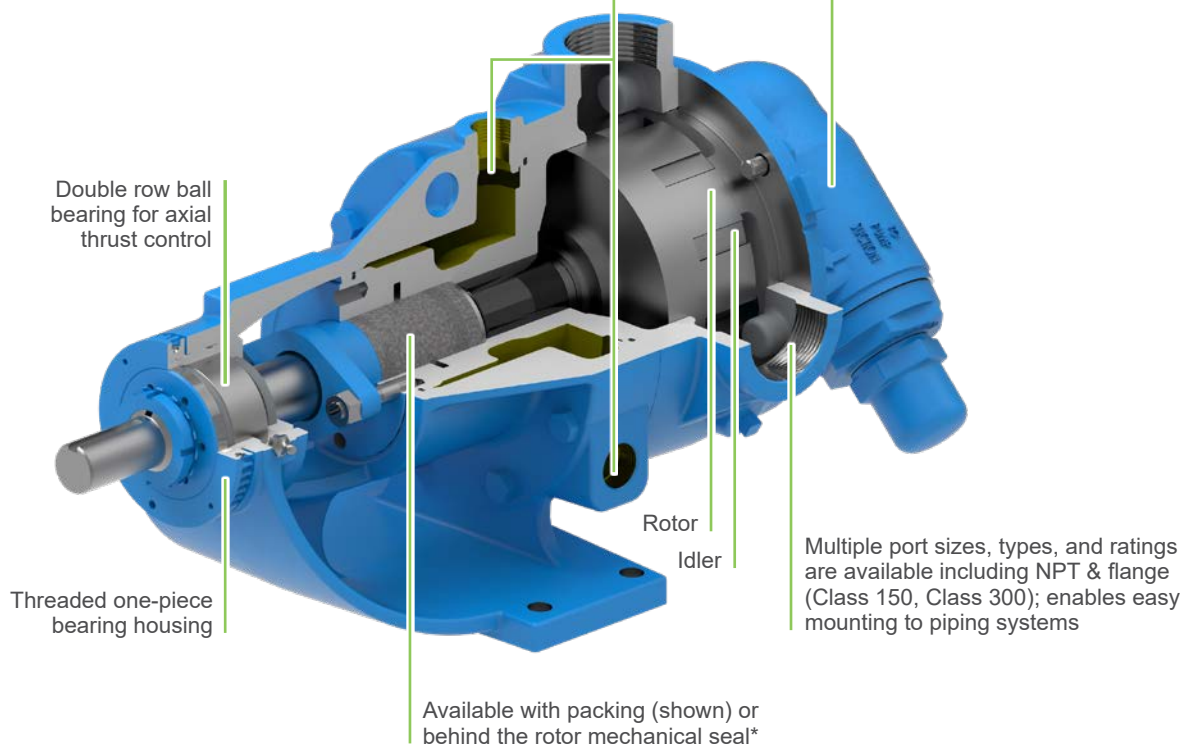

* Mechanical seal is in stuffing box only.



CAPACITY
to 110 GPM
(25 m³/h)



PRESSURE
to 150 PSI
(10 BAR)



VISCOSITY
28 to 2,000,000 SSU
(0.1 to 440,000 cSt)



TEMPERATURE
-120°F to +500°F
(-85°C to +260°C)

PERFORMANCE

MODELS		SPECIFICATIONS				
Jacketed		Performance			Standard Ports	
Packing	Behind the Rotor Seal	Max Speed, RPM	GPM	m ³ /h	Size, Inches	Type
F724*	F4724*	1750	1.5	0.3	0.5	NPT
FH724*	FH4724*	1750	3	0.7	0.75	NPT
G724*	G4724*	1150	5	1	1	NPT
H724	H4724	1750	10	2.3	1.5	NPT
HL724	HL4724	1750	20	4.5	1.5	NPT
K724	K4724	520	45	10	2	NPT
KK724	KK4724	520	65	15	2	NPT
L724	L4724	420	90	20	2	NPT
LQ724	LQ4724	420	90	20	2.5	Flange
LL724	LL4724	420	110	25	3	Flange

* Stuffing box seal, non-jacketed

CURVES

NON-JACKETED

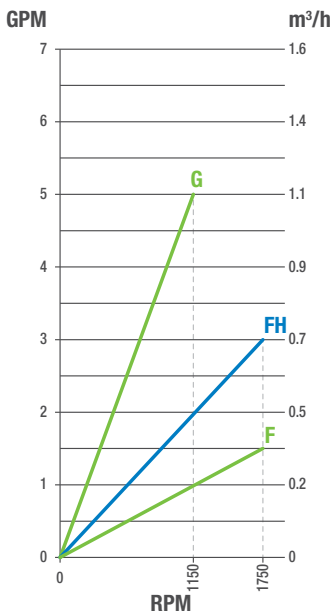

JACKETED

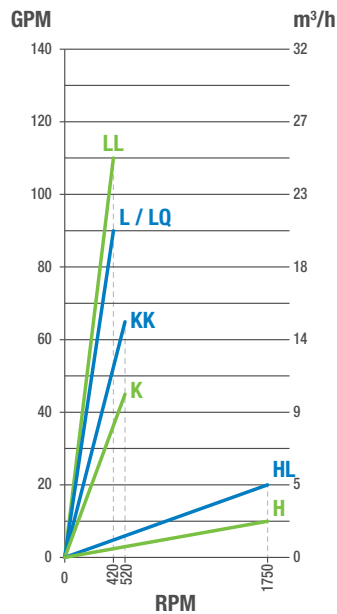

PORTING

- Right Angle (90°) (Rotatable Casing), H-LL
- Opposite (180°) (Rotatable Casing), F-G
- NPT / BSP
- Flanged (ANSI)

SEALING

- Packing
- Component Behind the Rotor Mechanical Seal, H-LL
- Component Mechanical Seal in Stuffing Box, F-G

MOUNTING

- Foot Mount

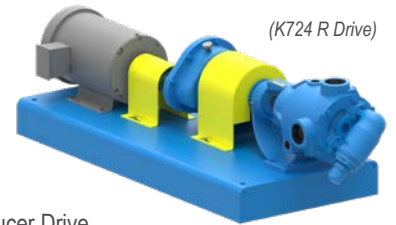

DRIVES

- Ⓡ Offset Gear Reducer Drive
- Ⓟ Purchased Gear Reducer Drive
- Ⓧ Direct-Mounted Drive
- Ⓥ V-Belt Drive

TYPICAL APPLICATIONS

- Soaps, Detergents & Surfactants
- Acids & Caustics
- Water-based Liquids
- Vegetable Oil
- General Chemicals



VIKING PUMP, INC.
 A Unit of IDEX Corporation
 406 State Street
 Cedar Falls, Iowa 50613 U.S.A.
vikingpump.com

CONTACT YOUR STOCKING DISTRIBUTOR TODAY

